



Welcome to warm water! We appreciate your business and look forward to providing you with years of relaxation and enjoyment. To ensure a seamless delivery of your new hot tub, please use these documents in preparation for the delivery of your new hot tub. Provided below are additional specifications for proper electrical setup.

Electric Installation

There are many ways that a hot tub can be wired **depending** on the exact model and/or brand that you purchase. This means that pre-existing wiring and electrical setups are not sufficient unless it is the exact same setup and model, assuming the manufacturer has not made any changes to the tub.

Your salesperson will provide you with electrical schematics for your new hot tub. Wiring schematics should be given to your electrician to ensure proper wiring of your hot tub.

115V hot tubs have a cord with a GFCI end and 10 ft of usable cord. The 20AMP receptacle box must be installed within 10 ft of the hot tub prior to delivery and the hot tub must be the only appliance powered on that circuit.

220V hardwired hot tubs need a “whip” (a flexible or hard $\frac{3}{4}$ ” conduit containing wires as specified on your tub wiring schematic) from your subpanel to the electrical cutout on the hot tub. You or your electrician **MUST** add additional length in wiring from the opening or where the electrical cutout is shown as an entry point on the hot tub **PLUS** the width and height of the equipment compartment for the final connection to be made. There is an electrical board inside the equipment compartment that the wires are meant to be connected and installed in order to run the hot tub (wires don’t just go into the electrical opening). This ensures that your electrician will have enough slack to connect the wires inside the hot tub. Too long is better than too short (we can wind the excess up in the equipment compartment). If the wires are too short your electrician will have to run an entire new set of wires for the hot tub to run properly and we will not be able to start your hot tub on delivery. Please have your electrician reach out to your local store or salesperson for any clarity needed.



PLEASE NOTE (common error):
The neutral wire in the

subpanel needs to be attached to the breaker, **NOT** on to the grounding bar. The hot tub may not start or the breakers may trip if the neutral wire is not connected properly.

WATKINS MANUFACTURING – “To ensure you will have an opportunity to use your spa soon after delivery, it is very important that the required electrical service has been installed. Unless otherwise stipulated by your dealer, **THIS IS YOUR RESPONSIBILITY.**

IMPORTANT: All electrical circuits must be installed by a qualified, licensed electrician.”

You can NOT run a hot tub on an extension cord.



Considering converting your Hot Tub from 110V to 220V?

Currently the hot tub models that are able to be converted from 110V to 220V are the Prodigy 2022 and prior, Jetsetter, Beam, Stride, SX, TX, and all FreeFlow hot tubs. Review the Pros and Cons to see if converting the electrical of your hot tub is a good option for you.

Contact your salesperson if you would like to convert to 220V.

110 V, 20A GFCI Cord 115V 15 A GFCI Cord 110V Plug N' Play
<p style="text-align: center;"><u>Pros</u></p> <ul style="list-style-type: none">• Ease of installation. <p style="text-align: center;"><u>Cons</u></p> <ul style="list-style-type: none">• Hot tub heater does not operate when jets are in use. Can lose 2-3 degrees per hour depending on the ambient temperature. (110V averages 24hrs to heat depending on size) <p style="text-align: center;"><u>Example of 110V- 15A:</u></p>



220V 50A Subpanel
<p style="text-align: center;"><u>Pros</u></p> <ul style="list-style-type: none">• Hot tub heats 4X quicker than 110V (110V averages 24hrs.)• Jets and heater operate at the same time. No temperature loss while using hot tub. <p style="text-align: center;"><u>Cons</u></p> <ul style="list-style-type: none">• Higher installation cost.• Requires additional programming on installation of hot tub. <p style="text-align: center;"><u>Example of 220V:</u></p>



SOVEREIGN

Shell: Alpine White
Cabinet: Brushed Nickel



LEGENDARY MASSAGE

- 32 Personalized-Control Jets
- Moto-Massage® Lounges
- Soothing Stream® Seat
- Precision® Jet Seat
- Hydromassage Seat

EASY WATER CARE

- Water Care System **SpaWorks®** Salt System Ready
- Filtration System 100% M4-bypass Filtration
Exclusive, High-Flow Tri-8® Filters
185 sq. ft. Filtration Area

LEADING ENERGY EFFICIENCY

- Jet Pump **SpaWorks®** 9000; Two-speed, 2.5 HP Continuous Duty, 5.2 HP Breakdown Torque
- Circulation Pump **SpaWorks®** 5000® for quiet, continuous filtration
- Heater Titanium No-Fault® 6,000 W / 230 V
- Insulation Multiple Layers of Foam Insulation; Certified to California Energy Commission (CEC) and APSP 14 energy efficiency standards for portable [spas](#)
- Cover 3.5" to 2.5" tapered, 1.5 lb. density foam core, with hinge [seat](#)

SIZE

Dimensions 6'8" x 7'9" x 33" / 203 cm x 236 cm x 84 cm

CAPACITY

- Seating Capacity 5 seats
- Water Capacity 330 gallons / 1,250 liters
- Weight 600 lbs. / 270 kg dry; 4,230 lbs. / 1,920 kg filled**

SHELL COLORS



CABINET COLORS



COVER COLORS

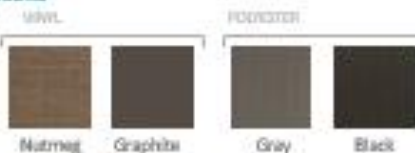

CABINET AND SHELL COLOR OPTIONS*

Blackwood	Linen	Brushed Nickel	Java	Charcoal
Alpine White	Alpine White	Alpine White	Alpine White	Alpine White
Ice Gray	Ivory	Ice Gray	Ice Gray	Ice Gray
Platinum	Tuscan Sun	Platinum	Ivory	Platinum
	Pebble		Tuscan Sun	Tuscan Sun
			Pebble	Pebble

ADDITIONAL FEATURES

- Water Feature **SpaWorks®** with 3 literated jets of water
- Cover Lifters **SpaWorks®**, **SpaWorks®**, or **Lite®** (F/B only)
- Steps [Steps](#) are available to match cabinet [colors](#)
- Entertainment Bluetooth® Wireless Sound System (Optional)
- Control System IQ 2020® with wireless remote control
230 V / **50-amp**, 60 Hz
[Includes](#) G.F.C.I. protected sub-panel
- Lighting System Luminescence® multi-color four-zone

Site Selection and Preparation

IMPORTANT: Site selection and preparation are your responsibility. Carefully read these instructions and consult your authorized **HOT SPRING** dealer if you have any questions.

You probably have a spot picked out for your new spa, whether it's indoors or outdoors, on a patio or on a deck. Just make sure you check the following:

- Always put your spa on a structurally sound, level surface. A filled spa can weigh a great deal. Make certain that the location you choose can support the weight of your filled spa.
- Locate your spa away from any reflective surface or glass. The heat generated by some types of double-pane windows and reflective surfaces can cause serious damage to the exterior of the spa, including the siding and cover.
- Locate your equipment compartment, which houses all of the electrical components, in a place where water will drain away from it. Allowing water into the equipment compartment can damage the electronics, or may result in tripping your house's circuit breaker.
- Leave yourself easy access to the circuit breakers in the subpanel (230 volt models), or to the interrupter switch on the end of the power cord (115 volt models).
- Never let water get into the subpanel (230 volt models), into the interrupter switch (115 volt models), or into the electrical outlet that your spa is plugged into. Your 230 volt spa's subpanel is raintight when installed correctly with the door closed.
- Leave access to the equipment compartment for periodic spa care and maintenance.

OUTDOOR AND PATIO INSTALLATION

No matter where you install your new spa, it's important that you have a solid foundation to support it. Structural damage to the spa resulting from incorrect installation or placement on an inadequate foundation is not covered under the spa's limited warranty.

If you install the spa outdoors, a reinforced concrete pad at least four inches thick is required for the Grandee® & Envoy® spas, and recommended for the Vanguard®, Aria®, Sovereign®, Prodigy® and Jetsetter® spas. The reinforcing rod or mesh in the pad should be attached to a bond wire (see your Owner's Manual). All Hot Spring spas may be installed onto a deck, provided that the load capacity of the deck is greater than the dead weight of the spa (see Deck Installation).

If you place the spa on the ground, even temporarily, place stepping stones under the leveling areas. The stones should be at least two inches thick and twelve inches square. Even with stones in place, the spa will inevitably settle and become unlevel. Plus, a spa surrounded by dirt or grass will soon be filled with dirt or grass from users' feet; therefore, it is important to get it onto a solid foundation as soon as possible.

DECK INSTALLATION

To be certain your deck can support your spa, you must know the deck's maximum load capacity. **Consult a qualified building contractor or structural engineer before you place the spa on an elevated deck or indoors.** To find the weight of your spa, its contents and occupants, refer to the Spa Specification chart. This weight per square foot must not exceed the structure's rated capacity, or serious structural damage could result.

INDOOR INSTALLATION

Be aware of some special requirements if you place your spa indoors. Water will accumulate around the spa, so flooring materials must provide a good grip when wet. Proper drainage is essential to prevent a build-up of water around the spa. When building a new room for the spa, it is recommended that a floor drain be installed. The humidity will naturally increase with the spa installed. Water may get into woodwork and produce dryrot, mildew, or other problems. Check for airborne moisture's effects on exposed wood, paper, etc. in the room. To minimize these effects, it is best to provide plenty of ventilation to the spa area. An architect can help to determine if more ventilation must be installed.

Your **HOT SPRING** dealer can help you with local information such as zoning regulations and building codes.

DELIVERY ACCESS

First, locate the dimensions of your spa on the following chart. The dimensions shown are the measurements of the spa in the vertical position, laid on its side.

Next, contact your dealer to find the height and width added by the delivery cart which the dealer will use to deliver your new spa. Use the height of the cart plus the dimension shown as H to determine the vertical clearance required to pass the spa and cart. Use the width of the cart, or dimension W, whichever is greater, to determine the maximum width of clearance necessary. Use the length dimension L when making any sharp turns to determine the maximum clearance required.

NOTE: It may be necessary to allow for additional over-head clearance if the spa will be rolled up or down an incline or moved up or down a short flight of stairs.

Use the information below to determine the requirements for access to your desired location.

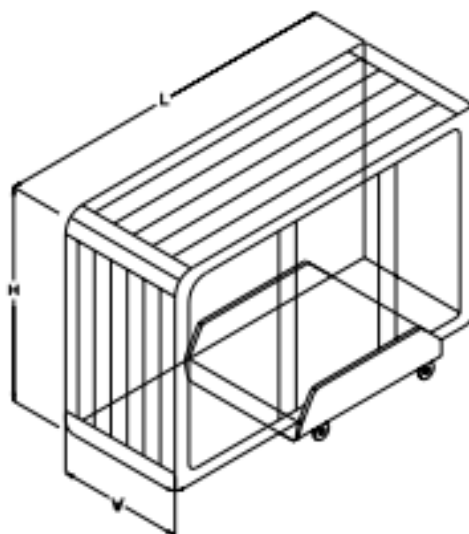

Model	Width W	Length L	Height H
GRANDEE (GGN)	38" (97 cm)	100" (2.54 m)	91" (2.31 m)
ENVOY (KKN)	38" (97 cm)	100" (2.54 m)	91" (2.31 m)
VANGUARD (VVN)	36" (91 cm)	87" (2.21 m)	87" (2.21 m)
ARIA (ARN)	36" (91 cm)	87" (2.21 m)	87" (2.21 m)
SOVEREIGN (IIN)	33" (84 cm)	93" (2.36 m)	80" (2.03 m)
PRODIGY (HN)	33" (84 cm)	84" (2.13 m)	78" (1.98 m)
JETSETTER LX (JTN)	33" (84 cm)	84" (2.13 m)	68" (1.73 m)
JETSETTER (JJN)	33" (84 cm)	84" (2.13 m)	68" (1.73 m)

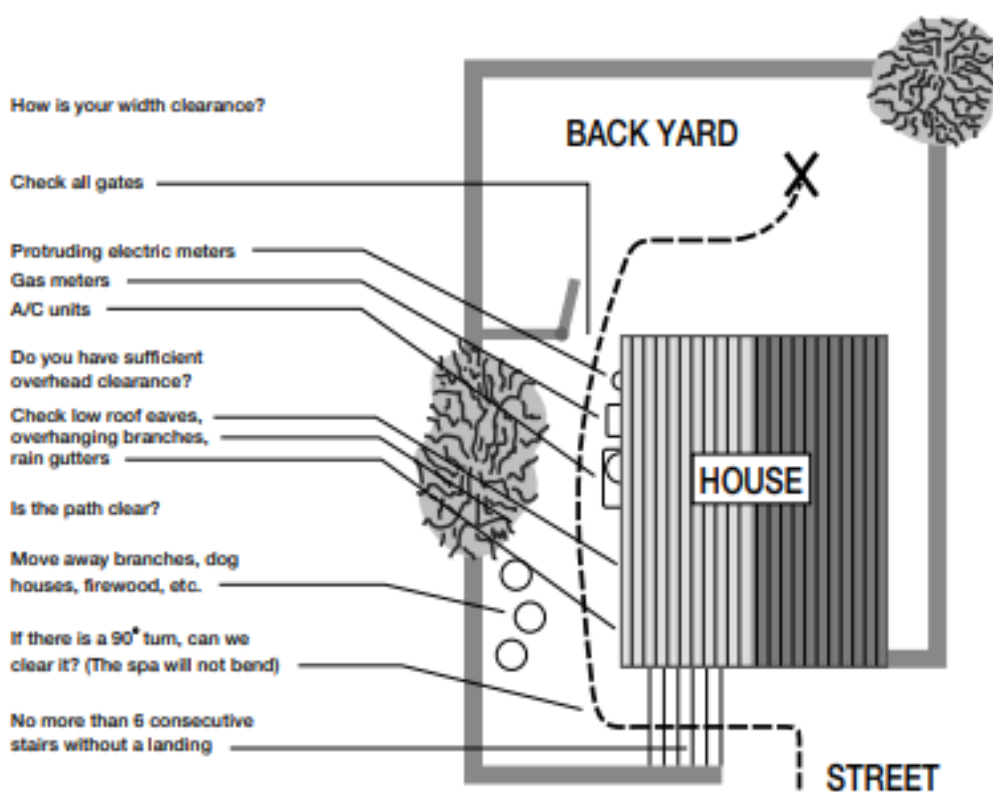

It may be necessary to remove a gate, part of a fence, or other movable obstructions in order to roll the spa to its installation site. About ten percent of the time, a crane is the only way to install the spa by lifting it to its final destination.

If the spa has to be taken off of the cart to go over a wall (either because the entry area is too narrow, the eaves are too low, the corner is too tight, or the stairway is too steep), a crane will be required. Don't be alarmed!

The crane has a truck-mounted boom which can fit right in your driveway. It is run by a licensed and insured operator. For a charge, the crane operator will lift your spa over walls, buildings, or any other obstruction and place it as close to the installation site as possible. The **HOT SPRING** spa delivery personnel will supervise the crane delivery and complete the spa installation.

NOTE: If your spa delivery requires the use of a crane, you may be required to pay for its services at the completion of the delivery.

GROUND PREPARATION

Your Hot Spring spa has been engineered to perform on several types of yard surfaces. While a concrete slab is recommended, other foundations (illustrated below) are acceptable so long as a level base is prepared prior to delivery. **NOTE:** Have a reinforced concrete pad at least 4 inches (10cm) thick or a deck that is able to withstand the pounds per square foot listed in the Spa Specification section.

INSTALLATION NOTES:

- Concrete sloped at 1/2 inch per 10 feet (1 cm per 3 m) is preferred so that rain water and water spillover will run off and not puddle underneath the spa.
- If brick or wood decking is selected for the spa foundation, it should be placed and leveled below the entire spa to maintain even distribution of the spa weight.
- It is important to note that if bricks are used to distribute the weight of the spa there may still be a tendency to settle unevenly, resulting in an unlevel spa.
- Remember, placing the spa around grass or dirt may increase the amount of debris which is inadvertently brought into the spa water on the user's feet.

If you are purchasing a deck package or a gazebo with your spa, a solid foundation becomes mandatory. Placing them on any surface other than a single level pad could create problems with their installation. Pictured at right are the recommended surfaces.

As a homeowner, it is your responsibility to provide a suitable, level foundation for your spa. Keep in mind that most delivery crews are not equipped to level and prepare spa sites.

If you are interested in having a concrete slab, brick surface, or wood deck installed, your **HOT SPRING** dealer should be able to suggest a qualified, licensed contractor.

NOTE: In order for the spa to operate properly and the internal plumbing to drain completely, you must ensure that the spa surface is leveled before the spa has been installed. Shimming or point leveling is **NOT** supported or recommended by the manufacturer.

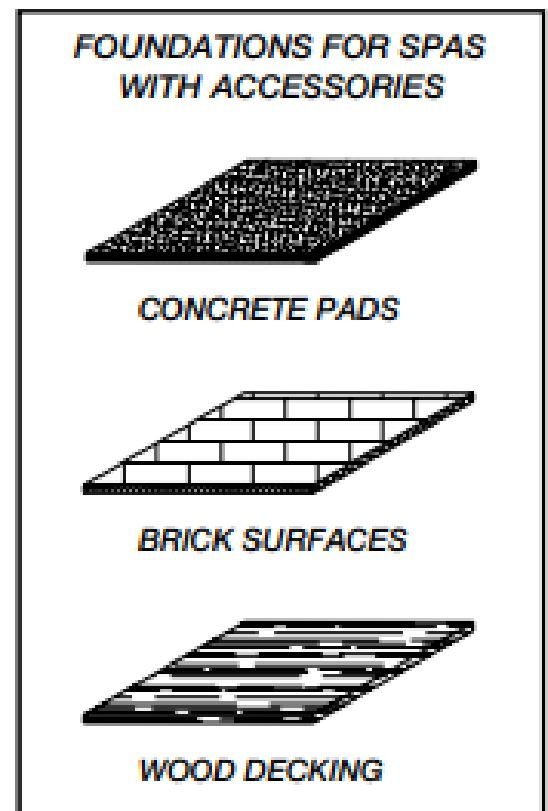

SOVEREIGN (IIN)

Dimensions

NOTE: All dimensions are approximate; measure your spa before making critical design or pathway decisions.

Configuration and location may change without notice.

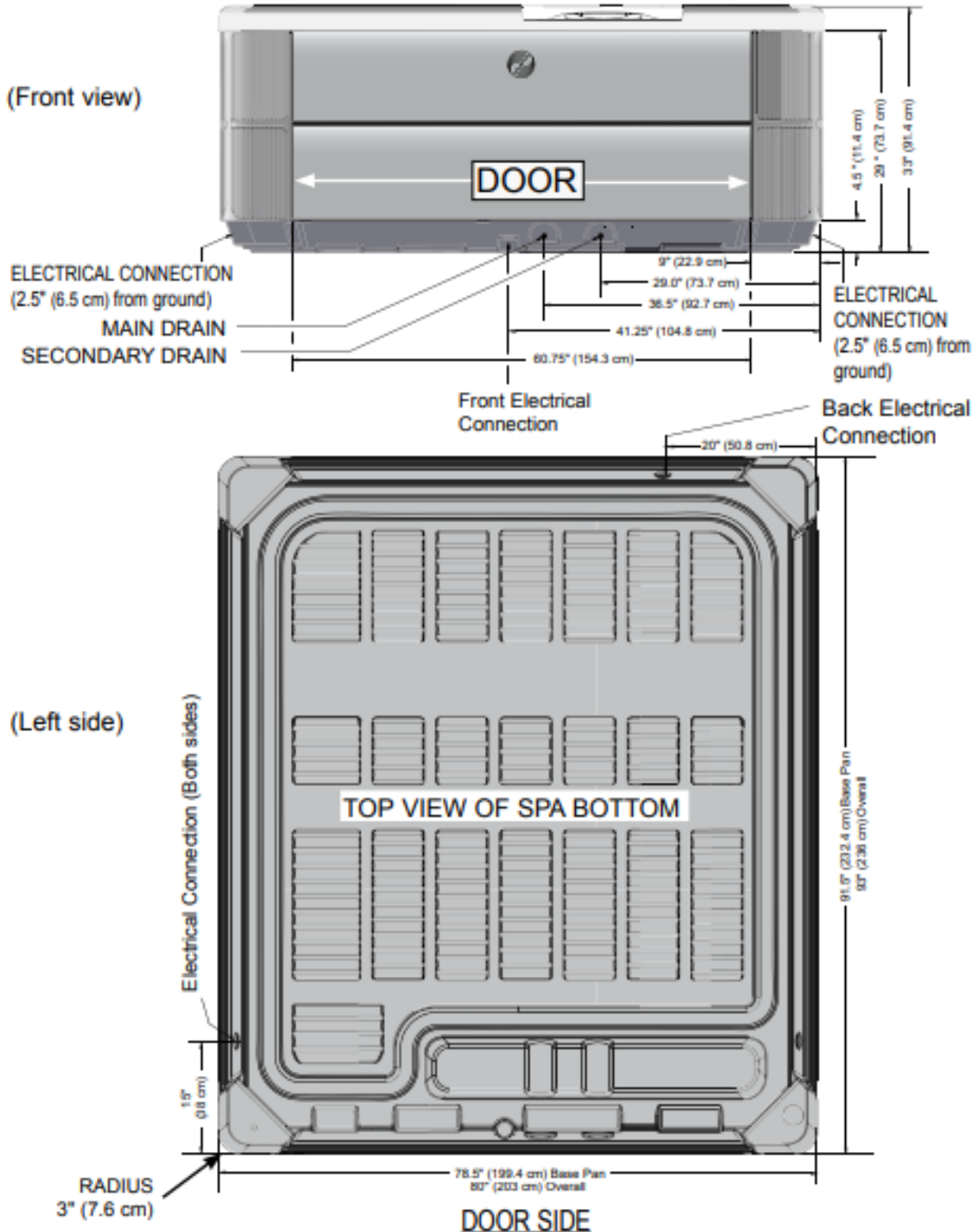

NOTE: WATKINS WELLNESS recommends that the **SOVEREIGN** be installed on a minimum 4" (10 cm) thick reinforced concrete pad or a deck that is able to withstand more than 115 lbs/ft² (555 kg/m²).

WARNING: The **SOVEREIGN** must not be shimmed in any manner.

230 VOLT OPERATION REQUIREMENTS

All models require a 50 amp, single phase, 230 volt circuit breaker in the main electrical service panel.

All 230 volt Hot Spring spas must be wired in accordance with applicable local and national electrical codes, all electrical work must be done by a licensed electrician.

NOTE: WATKINS WELLNESS REQUIRES THE USE OF A SUBPANEL TO SUPPLY POWER AND PROTECT THE SPA. The subpanel containing GFCI breakers is included with the spa except for **JETSETTER (JJN)**.

A licensed electrician should install a four-wire electrical service (two line voltages, one neutral, one ground) from the main electrical service panel to the subpanel, and from the sub-panel to the spa per the appropriate wiring diagram as illustrated below.

The grounding conductor must be at least #10 AWG. Your electrician should mount the subpanel in the vicinity of the spa but it should not be closer than 5 feet (1.5 m) from the spa water edge (NEC 680-38 to 41-A-3).

INSTALLATION NOTE: After the spa has been installed by the dealer's delivery crew, your electrician can connect the conduit from the subpanel to the spa's IQ 2020[®] Control Box and then complete the wiring connections in the control box.

IMPORTANT NOTE: Three different wiring diagrams are shown: one for **GRANDEE, ENVOY, VANGUARD & ARIA** models. One for the **SOVEREIGN, PRODIGY & JETSETTER LX** models, and one for the **JETSETTER JJN** model. Always follow the wiring diagram for your specific model.

NOTE: Complete Installation and Wiring Instructions for all 230 volt Hot Spring models are included in the Owner's Manual and with each sub-panel, which can be obtained from your dealer.

WARNING: Removing or bypassing the GFCI breakers in the subpanel at any time will result in an unsafe spa and will void the warranty.

WIRE SPECIFICATION NOTE: Long electrical runs may require a larger gauge feed wire than stated. We recommend that a maximum voltage drop of 3% be used when calculating the larger wire size.

Refer to the Wiring Diagrams to the right for the electrical requirements of the 230 volt models.

When connecting the supply conduit to the bottom of the **IQ 2020** box, use the recommended connectors, page is attached to the control box inside the spa.

SOVEREIGN (IIN), PRODIGY (HN) & JETSETTER LX (JTN)

230 volt permanently connected models

IMPORTANT!
THE EXACT PHYSICAL LOCATION OF THE TERMINALS ON THE GFCI BREAKER WILL VARY BETWEEN MANUFACTURERS. CONNECTING THE HOT WIRE TO THE NEUTRAL TERMINAL WILL CAUSE IRREVERSIBLE DAMAGE TO THE CONTROL BOX.

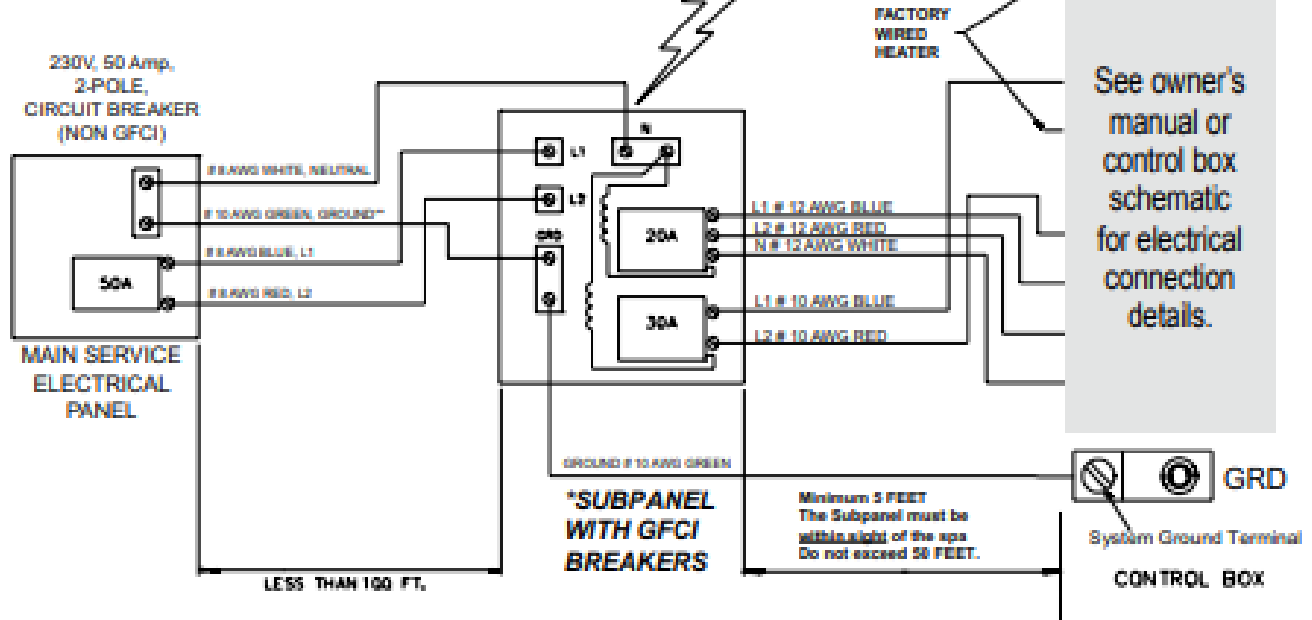

See owner's manual or control box schematic for electrical connection details.

** Refer to NEC 250-122 (table)

NOTE: The wire connections to GFCI breakers are for reference only. Always ensure the white neutral wire is connected to the load neutral of the 20 amp breaker.

***PROVIDED WITH HOT TUB.**

IMPORTANT: ALL WIRING SHOULD BE COPPER.